

PARTS LISTS

FREE WHEEL ASSEMBLY

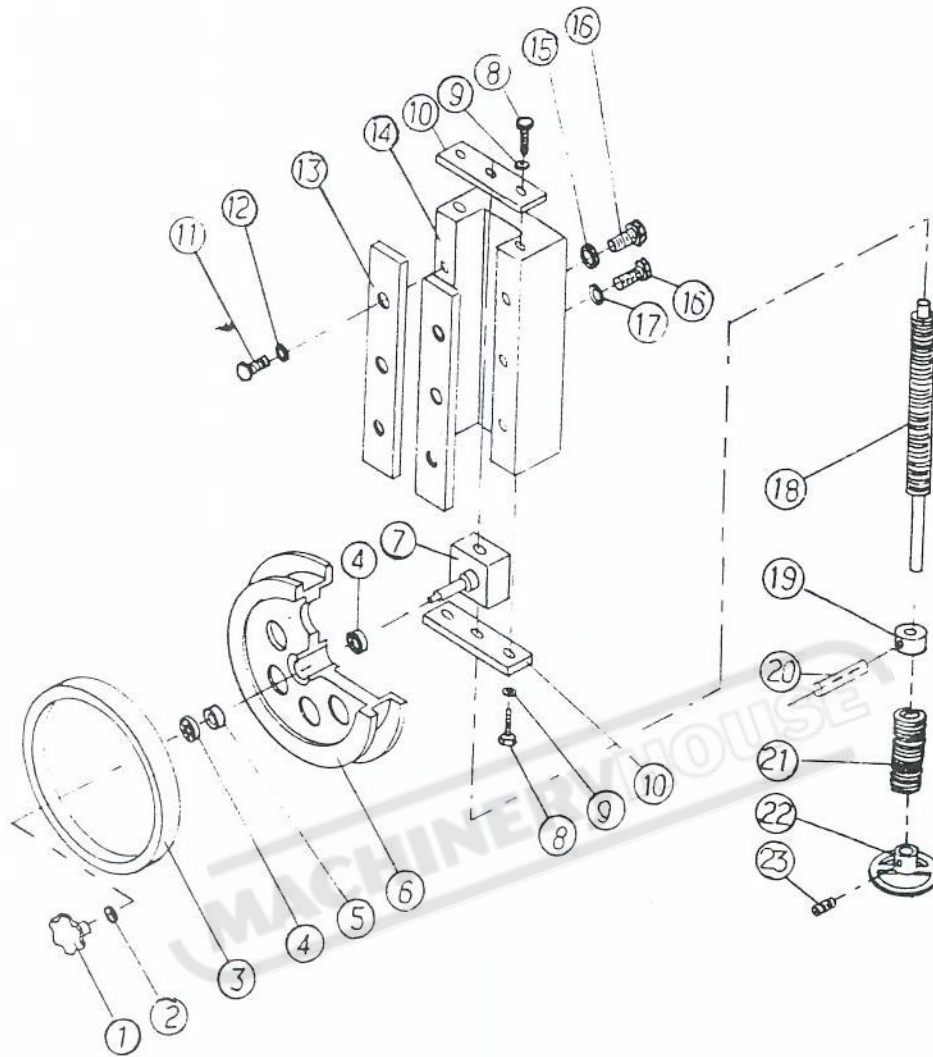

FREE WHEEL ASSEMBLY

INDEX NO.	PARTS NO.	DESCRIPTION	Q'TY
1		Lock Handle	1
2		Spring Washer 1/2"	1
3	(KB-30)	Rubber Tire	1
	(KB-36)		
	(KB-45)		
4		Bearing 6203ZZ	2
5	B-45303(KB-45 only)	Spacer	1
6	B-30301 (KB-30)	Free wheel	1
	B-36301 (KB-36)		
	B-45301 (KB-45)		
7	B-36306 (KB-30,36)	Sliding Block	1
	B-45304 (KB-45)		
8		Hex. Hd. Screw M8 x 20	4
9		Spring Washer 5/16"	4
10	E-36311	Plate	2
11		Hex. Hd. Screw M8 x 20	6
12		Spring Washer 5/16"	6
13	E-36312	Plate	2
14	E-36305	Sliding Block Guide	1
15		Nut M8x1.25	4
16		Hex. Hd. Screw M8 x1.25x30	8
17		Washer 5/16"	4
18	B-36307 (KB-30,36)	Tension Screw	1
	B-45305 (KB-45)		
19	B-36309	Fixed Ring	1
20		SPRING PIN 5x22	1
21	B-36310 (KB-30,36)	Spring	1
	V-40307 (KB-45)		
22		Handle	1
23		Lock Screw M8x1.25x10	1

POST AND UPPER SAWGUIDE ASSEMBLY

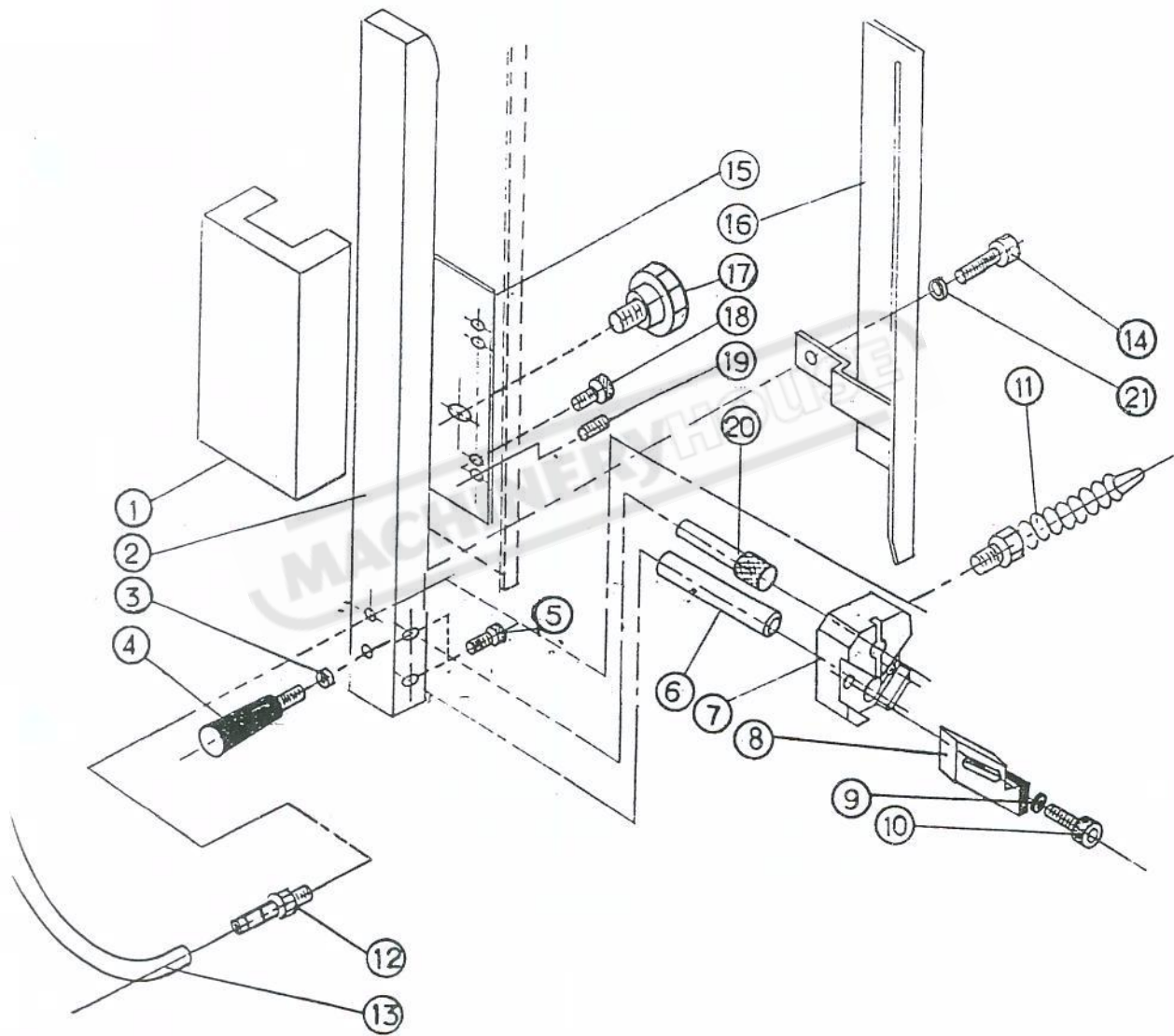

POST and UPPER SAWGUIDE ASSEMBLY

INDEX NO.	PARTS NO.	DESCRIPTION	Q'TY
1	B-36202(KB-30,36) V-40202 (KB-45)	Post Guide	1
2	B-36201(KB-30,36) V-40201 (KB-45)	Post	1
3		Spring Washer 5/16"	1
4		Handle	1
5		Socket Hd. Screw M6 x 15	2
6	B-36206 (KB-30,36) V-40207 (KB-45)	Back Up Support	1
7	B-36204 (KB-30,36) V-40204 (KB-45)	Upper Insert Holder	1
8	B-36205 (KB-30,36) V-40205 (KB-45)	Insert	2
9		Spring Washer 1/4"	2
10		Soc. Hd. Screw M6 x 20(KB-30,36) M6 x 25(KB-45)	2
11		Nozzle	1
12		Joint	1
13		Hose	1
14		Soc. Hd. Screw M6 x 10	2
15	B-36203 (KB-30,36) V-40203 (KB-45)	Post Guide Washer	1-3
16	B-36209 (KB-30,36) V-40209 (KB-45)	protector Cover	1
17		Handle	1
18		Soc. Hd. Screw M6 x 30	4
19		Lock Screw M8 x 15	4
20	B-36207 (KB-30,36) V-40208 (KB-45)	Support Bar	1
21		Washer 1/2"	2

TABLE and UNDER SAWGUIDE ASSEMBLY

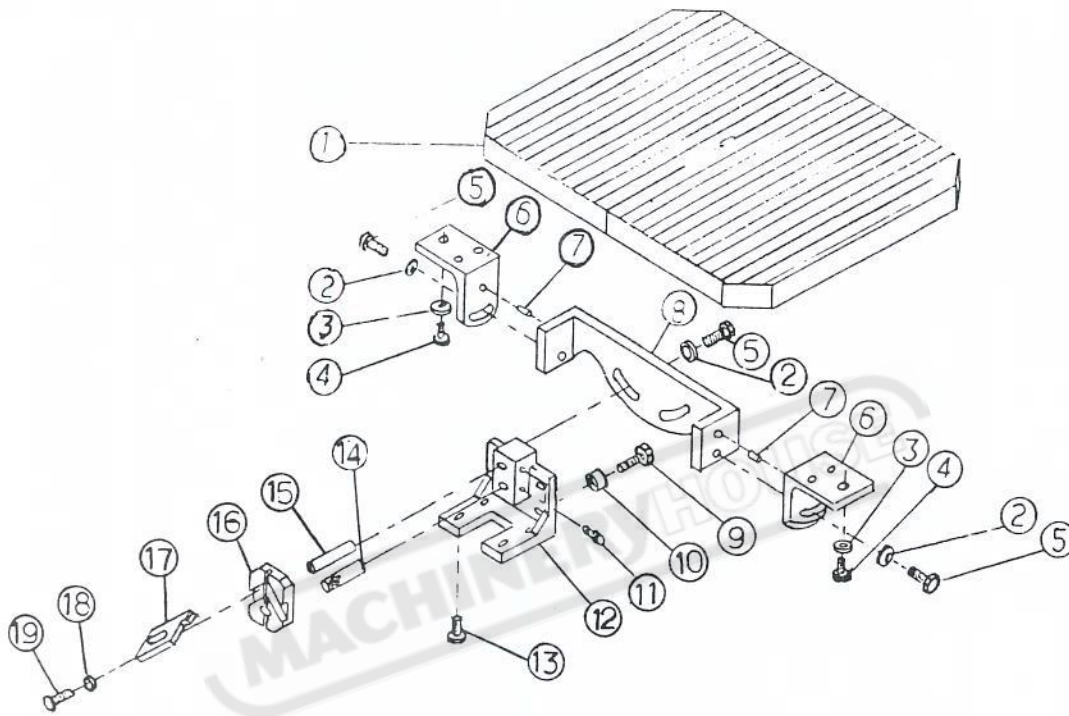
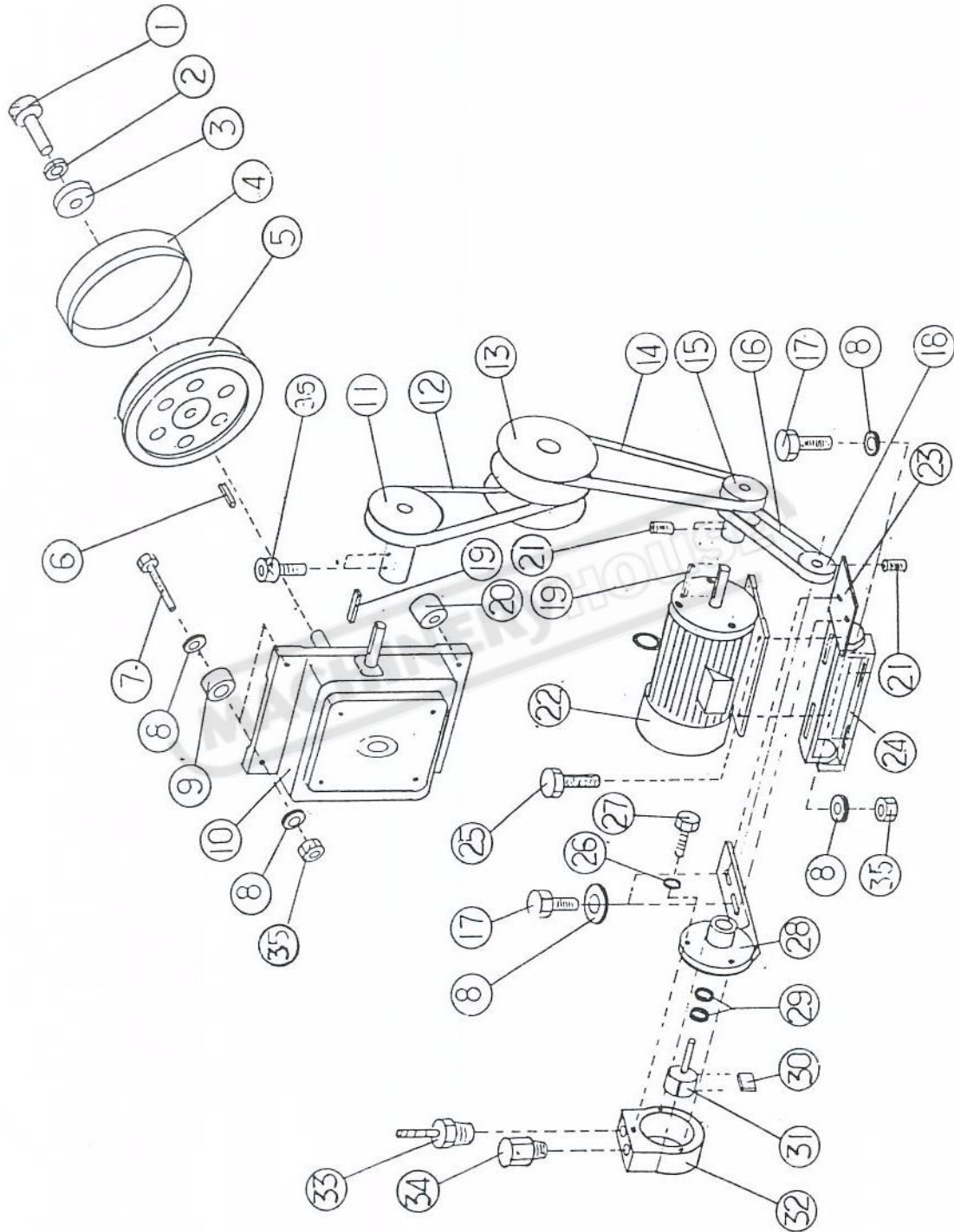

TABLE AND UNDER SAWGUIDE ASSEMBLY.

INDEX NO.	PARTS NO.	DESCRIPTION	Q'TY
1	B-36401 (KB-30,36)	TABLE	1
.	V-40401 (KB-45)	TABLE	1
2.	B-36409	WASHER	4
3.		WASHER 3/8"	4 (KB-45) 6PCS
4.		HEX.HD. SCREW M10x30	4 "
5.		HEX.HD.SCREW M10x50	4
6.	B-36402 /V-40402(KB-45)	BRACKET	2
7.	B-36407	PIN	2
8.	B-36403	BRACKET	1
9.	B-36405	SCREW	2
10.	B-36406	ROLLER	2
11.		SOC.HD.SCREW M6x25	2
12.	B-36404	TABLE BED	1
13.		HEX.HD.SCREW M10x25	4
14. (KB-30	B-36207 /V-40208(KB-45)	SUPPORT BAR	1
15. 36)	B-36206 /V-40207(KB-45)	BACK UP SUPPORT	1
16. "	B-36204 /V-40205(KB-45)	UNDER INSERT HOLDER	1
17. "	B-36205 /V-40206(KB-45)	INSERT	2
18.		SPRING WASHER 1/4"	2
19.		SOC.HD.SCREW M6x1.0x25	2

DRIVE ASSEMBLY



DRIVE ASSEMBLY

INDEX NO	PART NO	DESCRIPTION	Q'TY
1.		Socket Hd. screw M8x30	1
2.		Spring washer 3/8"	1
3.	B-36304	Spindle cover	1
4.	(KB-30)	Rubber	1
	(KB-36)		
	(KB-45)		
5.	B-30302(KB-30)	Drive wheel	1
	B-36302(KB-36)		
	B-45302(KB-45)		
6.		Key 7x7x25	1
7.		Hex,Hd screw M8x1.25x45	4
8.		Washer 3/8"	14
9.	B-36513-2(KB-30,36)	Reducer washer	2
	B-36513-3(KB-45)	Reducer washer	2
10.		Reducer	1
11.	B-36514 (KB-30,36)	Reducer pulley	1
12.	B-45517 (KB-45)	V-BELT A-29	1
13.		Variable speed pulley ass'y	1
14.	(KB-30,36)	V-BELT A-28	1
	(KB-45)	V-BELT A-29	1
15.	B-36516	Motor pulley	1
16.		V-BELT A-17	1
17.		Hex.Hd screw M8x1.25x20	4
18.	B-36601	Air induction pulley	1
19.		Key 5x5x35	1
20.	B-36513-1	Reducer washer	2
21.		Soc.Hd screw M8x1.25x10	3
22.	(KB-30)	Motor 1/2HP	1
	(KB-36,45)	Motor 1HP	
23.	B-36515-2	Air injection bracket	1
24.	B-36515-1	Motor bracket	2
25.		Hex. Hd screw M8x1.25x30	2
26.		Spring washer 1/4"	3

INDEX NO	PART NO	DESCRIPTION	Q"TY
27.		Hex.Hd screw M6x1.0x25	3
28.	B-36602	Air injection seat	1
29.		Bearing ;5201 ZZ	2
30.	B-36605	Air injection leaf	4
31.	B-36604	Air injection shaft	1
32.	B-36603	Air injection boday	1
33.	B-36606	Air out put hose nipple screw	1
34.	B-36607	Air in put hose nipple screw	1
35.		Nut M8x1.25	6

MACHINERYHOUSE

VARIABLE SPEED PULLEY ASSEMBLY

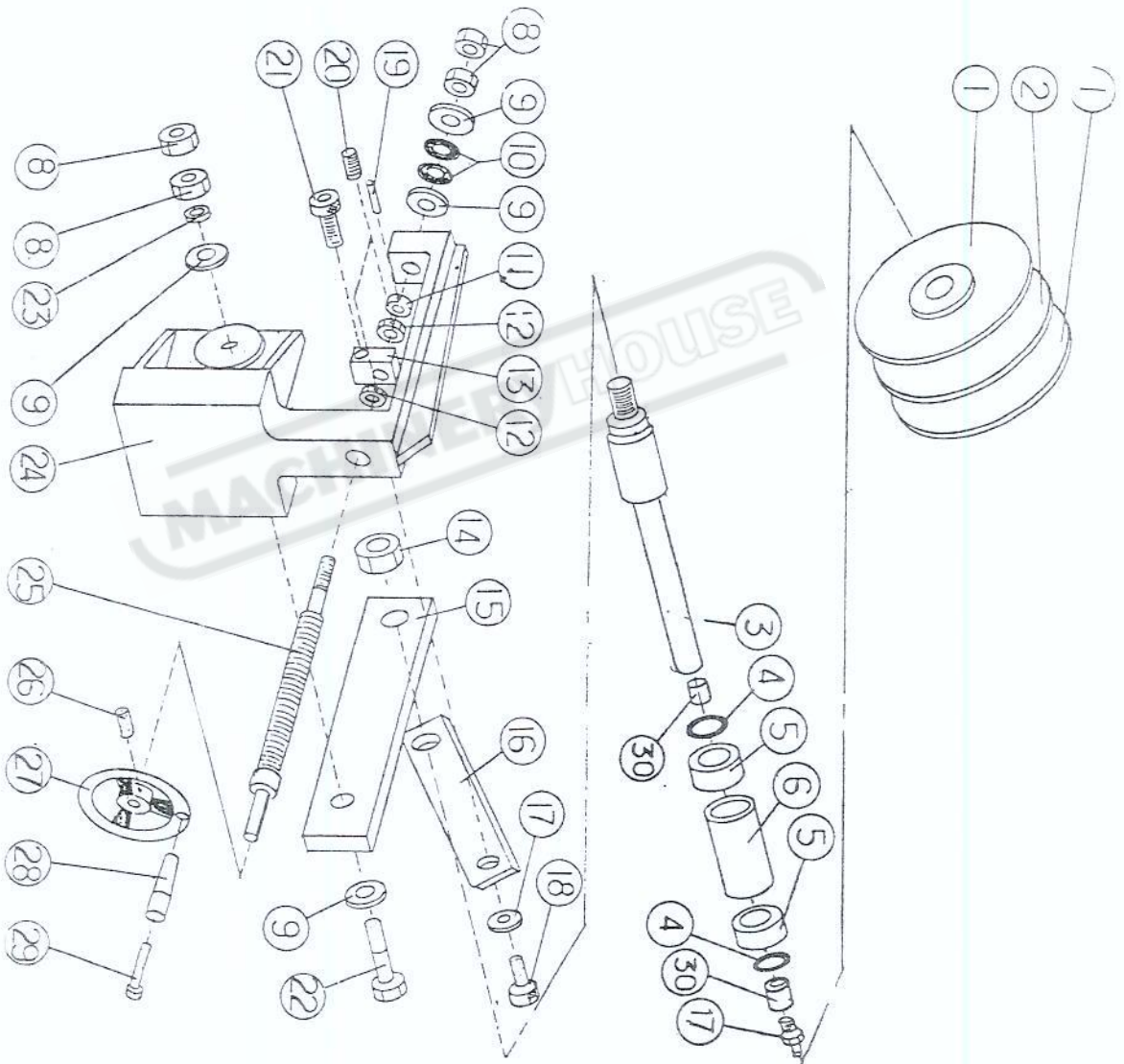

VARIABLE SPEED PULLEY ASSEMBLY

INDEX NO.	PART NO.	DESCRIPTION	Q'TY
1	B-36501	FIXED FLANCE	2
2	B-36502	MOVABLE FLANCE	1
3	B-36511(KB30)36)	SHAFT	1
	B-45511(KB-45)	SHAFT	1
4		OIL RING P-19	2
5	B-36518	COPPER SLEEVE SET	2
6	B-36503	BEARING SLEEVE	1
7		GREASE NIPPLE 1/8"PT	1
8		NUT M12x1.75	4
9		WASHER 1/2"	4
10		SPRING WASHER	2
11	B-36510	LEAD SCREW SLEEVE	1
12		NUT 5/8"-11NC	2
13	B-36509	VARIABLE SPEED SLIDING BLOCK	1
14		NUT 5/8"-18UNC	1
15	B-36507	KNUCKLE ARM	1
16	B-36508	VARIABLE FEED ROD	1
17		WASHER 3/8"	1
18		SOC.HD SCREW M8x1.25x15	1
19		PIN Ø3x21	1
20		SOC.HD SCREW M6x1.0x10	2
21		SOC.HD SCREW M8x1.25x20	1
22		HEX.HD SCREW M12x1.25x60	1
23		SPRING WASHER 1/2"	1
24	B-36506	SEAT	1
25	B-36505	LEAD SCREW	1
26		SOC.HD.SCREW M8x1.25x10	1
27		HANDLE WHEEL	1
28		HANDLE	1
29		HANDLE SHAFT	1
30		COPPER SLEEVE	2

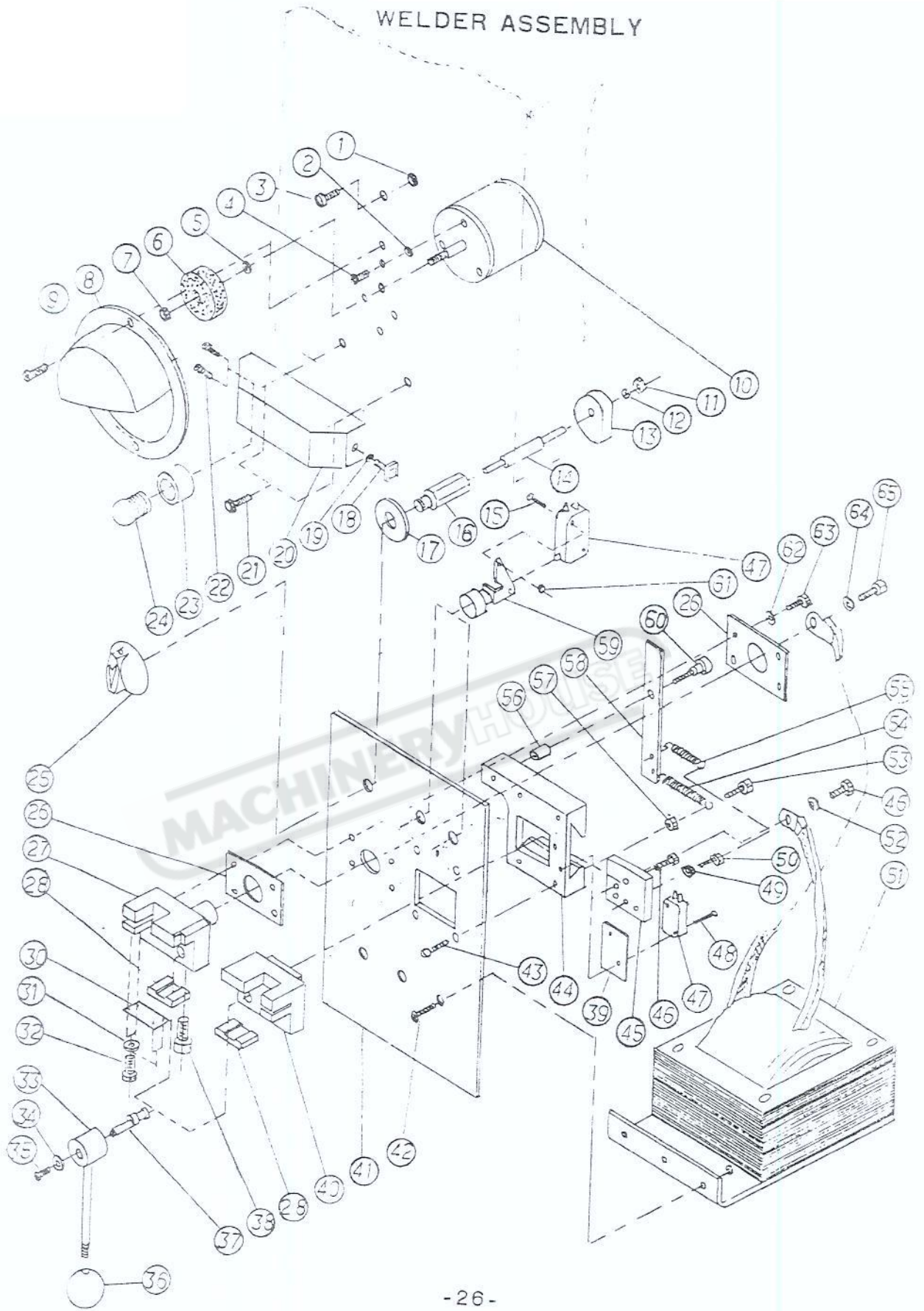

WELDER ASSEMBLY

INDEX NO.	PARTS NO.	DESCRIPTION	Q'TY
1		Nut M8	1
2		Washer 1/4"	4
3		Pilot Light	1
4		+ Round Hd. Scr. M6 x 1.0x15	4
5		Washer 5/16"	2
6		Grinding Wheel	1
7		Nut M6 x 1.0	1
8	B-36120	Protector Cover	1
9		+ Flat Hd. Screw M5 x 0.8x12	2
10		Grind Motor 1/8HP	1
11		Nut .5 x 1.0	1
12		Spring Washer 1/4"	1
13	W-16115	Cam	1
14	W-16111	Shaft	1
15		+ Round Hd. Scr. M3 x 0.5x12	4
16	W-16116	Tube	1
17		Washer 1/2"	1
18		One Point Switch	1
19		Nut M12	1
20	W-16101	Lamp Shade	1
21		Hex. Hd. Screw M6 x 1.0 x 15	2
22		+Round Hd. Scr. M3 x 0.5x10	2
23		Lamp Hd.	1
24		Lamp 5W 110V or 24V	1
25		Pressure Knob	1
26	W-16112	Insulating plate	2
27	W-16104	Fixed Pole Jaw	1
28	W-16107	Lower Fixed Block	2
30	W-16108	Connect Plate	2
31		Spring Washer 1/8"	8
32		+ Round Hd. Scr. M3 x 0.5x5	8
33	W-16109	Tight Handle (left)	1
	W-16110	Tight Handle (right)	1

34		Washer 3/16"	2
35		- Round Hd. Scr. M4x0.7x10	2
36		Plastic Ball	2
37	W-16111	Eccentric shaft	2
38		Rd. Hd. Screw M5x0.8x10	2
39		Insulating Plate 20 x 35 x 0.5	1
40	W-16103	Slide Pole Jaw	1
41	W-16102	Pannel	1
42		+ Flat Hd. Scr. M6 x 1.0x8	3
43		+ Flat Hd. Scr. M6 x 1.0x10	4
44	W-16105	Slide Track	1
45	W-16106	Slide Block	1
46		Rd. Hd. Screw M6 x 1.0x10	4
47		Micro Switch V-1A	2
48		+ Round Hd. Scr. M3x0.5x15	2
49		Nut M6x1.0	.
50		Rd. Hd. Screw M6 x 1.0x15	1
51		Transformer 2.4KVA	1
52		Washer 1/4"	1
53		Rd. Hd. Screw M6 x 1.0x15	1
54		Tension Spring $\phi 1 \times \phi 10 \times 30$	1
55		Tension Spring $\phi 1 \times \phi 10 \times 20$	1
56	W-16120	Spacer	1
57		Nut M6	1
58	W-16118	Spring lever	1
59		Push Button Switch	2
60	W-16117	Screw	1
61		Nut M3 x 0.5	4
62		Washer 1/4"	4
63		RD. Hd. Screw M6 x 1.0x12	4
64		Washer 1/4"	1
65		RD. Hd. Screw M6 x 1.0x10	1

MACHINE BODY ASSEMBLY

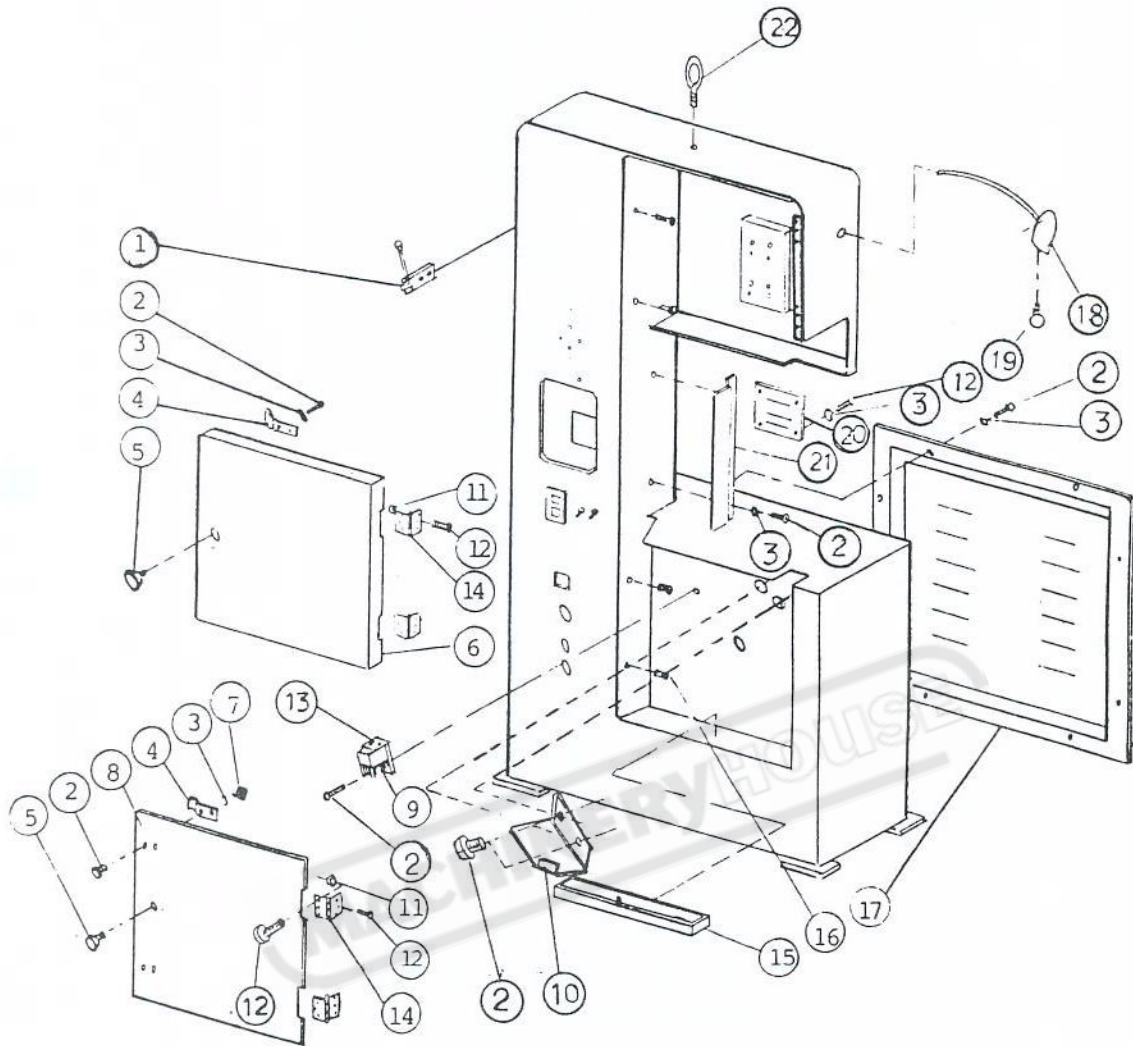

MACHINE BODY ASSEMBLY

INDEX NO.	PARTS NO.	DESCRIPTION	Q'TY
1	B-36140	Blade Shear	1
2		+Rd. Hd. Scr. M6x1.0x10 (KB-45)	19
		-do- (KB-30,36)	17
3		Washer 1/4" (KB-45)	19
		-do- (KB-30,36)	17
4	B-36115	Snap Catch (KB-36,45)	4
		-do- (KB-30)	3
5		Holder	2
6	B-36111	Upper Door (KB-36)	1
	B-30111	(KB-30)	1
	B-45111	(KB-45)	1
7		Nut M6x1.0	4
8	B-30112	Lower Door (KB-30)	1
	B-36112	(KB-36)	1
	B-45112	(KB-45)	1
9		Chip Brush	1
10	B-36116	Chip Plate	2
11		Nut M6x1.0	12
12		+Rd. Hd. Screw M5x0.8x10	24
13	B-36117	Chip Brush Holder	1
14		Hinge (KB-30,36)	4
		(KB-45)	4
15	B-36118	Chip Box (KB-30,36,45)	1
16		+Rd. Hd. Screw M4x0.7x10	4
17	B-30113	Rear Cover (KB-30)	1
	B-36113	(KB-36)	1
	B-45113	(KB-45)	1
18		Working Lamp	1
19		Lamp 60W 110V/24V	1
20	B-36114	Cover	1
21	B-36119	Blade Protection (KB-30,36)	1
	B-45119	Blade Protection (KB-45)	1
22		HANGER	1